



Snap-on

L5 Connect™ ATC Portal Installation Guide

Version 1.0

ATC PORTAL

Traig Born
8-8-2023

This Page Left Bank

SAFETY INFORMATION

For your safety, read this manual thoroughly before the installation of the equipment.

Installation is intended to be performed by properly trained technicians. The safety messages presented here are reminders to the installer to exercise extreme caution during installation and training on the system.

There are many variations in procedures, techniques, tools, and parts for installation due to varied shop configurations. Because of the vast versatility of installation, the manufacturer cannot possibly anticipate or provide advice or safety messages to cover every situation. It is the technician's responsibility to be knowledgeable of the equipment to be installed. It is essential to use proper service methods and perform installation in an appropriate and acceptable manner that does not endanger your safety, the safety of others in the work area, the end-user, or the equipment being serviced.

It is assumed that, prior to the installation of the system, the operator has a thorough understanding of Automated Tool Control Systems in general. In addition, it is assumed they have the proper hand and power tools necessary to perform the installation, operation, and training in a safe manner.

These safety precautions should always be followed, including:

1. Read all instructions.
2. Care must be taken as burns can occur from touching hot parts.
3. Do not operate power tools or equipment with a damaged power cord or if the equipment has been dropped or damaged until it has been examined by a qualified serviceman.
4. Do not let the cord hang over the edge of the table, bench, or counter or come in contact with hot manifolds or moving fan blades.
5. If an extension cord is necessary, a cable with a current rating equal to or more than that of the equipment should be used. Cords rated for less than the equipment may overheat. Care should be taken to arrange the cable so that it will not be tripped over or pulled.
6. Always unplug equipment from the electrical outlet when not in use. Never use the cord to pull the plug from the outlet. Grasp plug and pull to disconnect.
7. Let equipment cool entirely before putting it away. Loop cord loosely around equipment when storing.
8. To reduce the risk of fire, do not operate equipment in the vicinity of open containers of flammable liquids, such as gasoline.
9. Adequate ventilation should be provided when working on operating internal combustion engines.
10. Keep hair, loose clothing, fingers, and all parts of the body away from moving parts.
11. To reduce the risk of electrical shock, do not use it on wet surfaces or exposed to rain.
12. Use the device only as described in this manual. Use only the manufacturer's recommended attachments.
13. ALWAYS WEAR SAFETY GLASSES. Everyday eyeglasses only have impact-resistant lenses. They are NOT safety glasses.
14. Know and understand the proper operating procedures for all power tools used.
15. If the equipment is used in a manner not specified by the manufacturer, the protection provided by the equipment may be impaired.
16. Danger: Mirror could have sharp edges, be careful of cuts along the edge of the glass when cleaning!!!

IMPORTANT!! SAVE THESE INSTRUCTIONS

DO NOT DISCARD!!



SAFETY INSTRUCTIONS IMPORTANT!! SAVE THESE INSTRUCTIONS



Risk of electrical shock.

- Do not operate equipment with a damaged power cord or if the equipment has been dropped or damaged until it has been examined by a qualified service person.
- If an extension cord is necessary, a cable with a current rating equal to or greater than that of the equipment should be used. Lines rated for less present than the equipment can overheat.
- Unplug equipment from the electrical outlet when not in use. Never use the cord to pull the plug from the outlet. Grasp plug and pull to disconnect.
- Do not expose the equipment to rain. Do not use it on wet surfaces.
- Plug the unit into the correct power supply.
- Do not remove or bypass the grounding pin.
- Do not use a replacement main power cord that does not meet the power rating of the original cable. SJTW 18/3 105°C, 10', 10A/125-240-VAC

Contact with high voltages can cause death or severe injury.



Risk of electrical shock. High voltages are present within the console unit.

- Service on the unit must be performed by qualified personnel.
- Do not open any part of the control shelf other than the noted areas.
- Turn the power switch off and unplug the unit before servicing.

Contact with high voltages can cause death or severe injury.



Units can tip or strike you.

- Do not open more than one loaded drawer at a time.
- Keep children away
- Close lid and lock drawers and doors before moving.
- Apply brakes on locking casters when not moving unit.
- Do not step in or on drawers.
- Secure units together with fasteners.
- Read the instruction manual.



Tipping of storage unit or unit striking you can cause injury.



Unit's edges can cut or pinch.

- Do not pull unit; push to move.
- Wear gloves when lifting by edges.
- Keep feet and fingers clear of edges when stacking hanging or moving units.

Unit's edges can cause injury.



Do not dispose a landfill.

- The unit contains electronics that must be disposed of within the bounds of EN 50149.
- Dispose of lithium-ion batteries (where applicable) in accordance with local laws.
- For more information, call 1-800-424-9300 for North America or 1-703-527-3887 for International.

SAVE THESE INSTRUCTIONS

Table of Contents

ATC Portal Setup	7
Tools Required	7
Camera Setup.....	15
Receipt Printer Setup.....	17
Troubleshooting.....	18
Body Mass Sensors.....	18
Front Door Magnets.....	18
Emergency Exit Button.....	19
RFID Errors	19



ATC Portal Setup

Tools Required

- #2 Phillips Screwdriver
- 1/8" Hex Ball End Driver
- ¼" Hex Ball End Driver
- 3/16" Hex Ball End Driver

DO NOT ATTACH POWER CABLE INTO OUTLET UNTIL LAST STEP.

1) Upon arrival, check the following:

- Damage to the pallet and/or wrapping.
- Status of "TipNTell" – may indicate rough handling.
- Note any damage or irregularities on shipping document.
- **DO NOT SIGN FOR SHIPMENT IF ANY DAMAGE HAS OCCURRED. REFUSE THE SHIPMENT.**

2) Separate and unwrap all pieces. Be sure to leave the stickers with the pieces to identify them.

3) Place the Left and Right-side frames on their respective sides of the opening where they will sit.

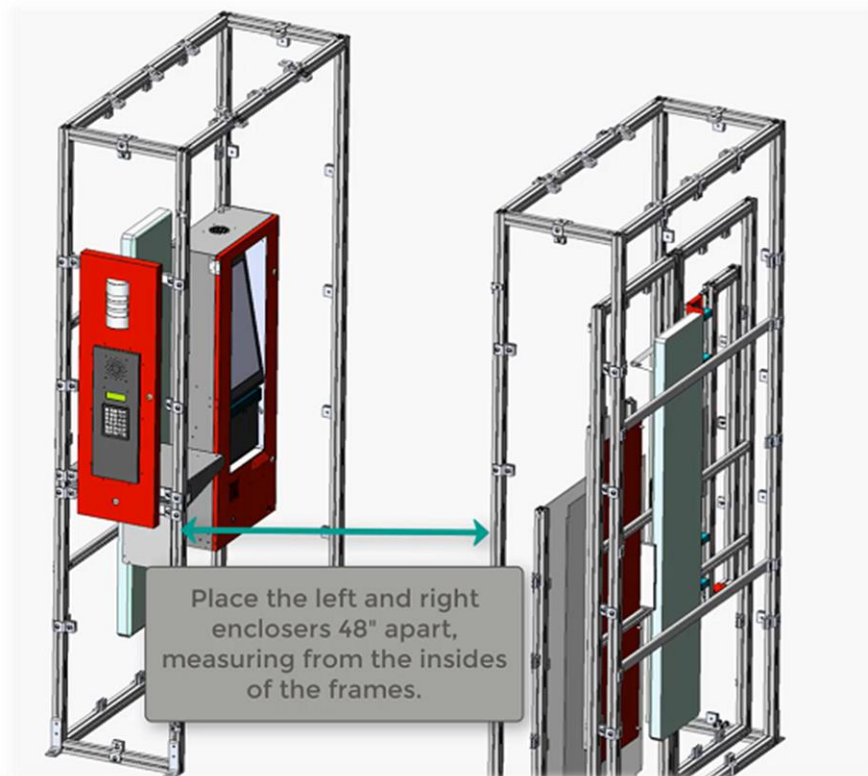

4) Install the Front Header assembly.

- Turn the Front Header assembly so that you have access to the bottom of the assembly.

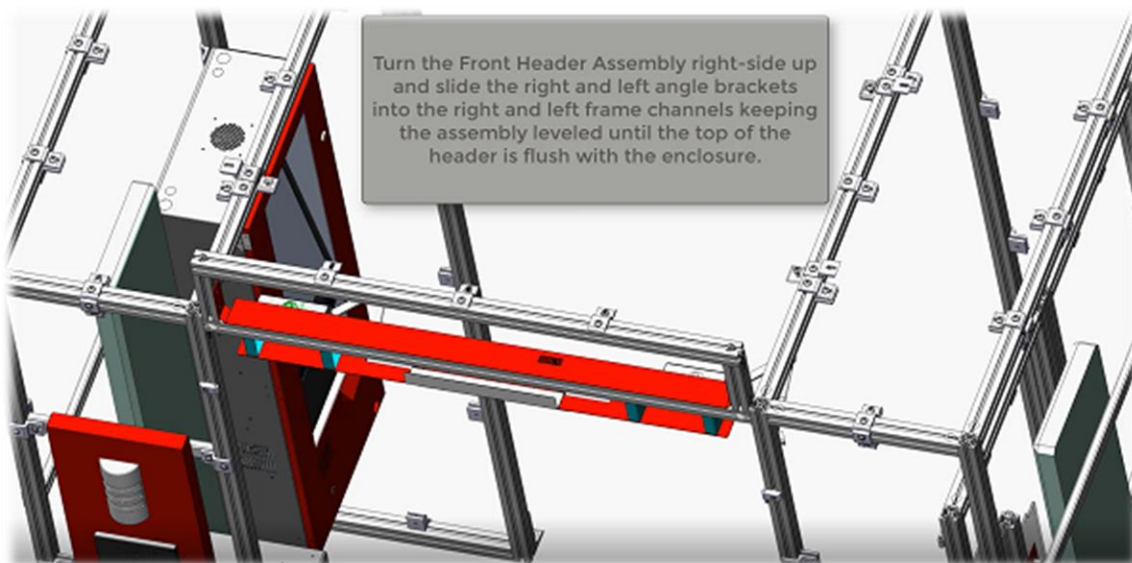
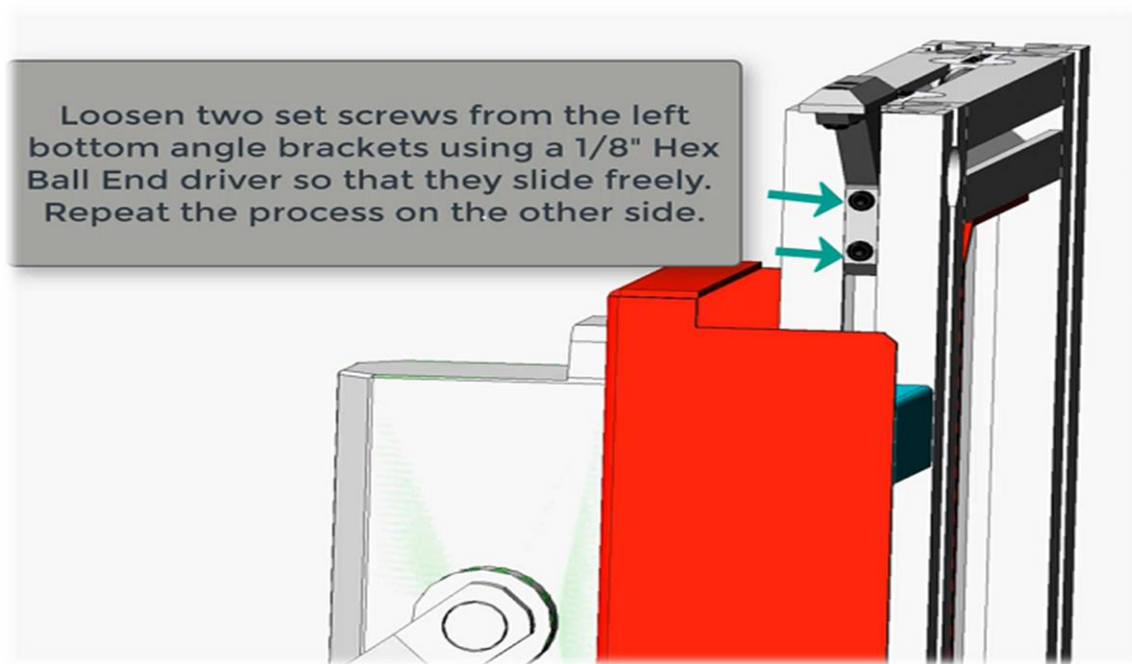

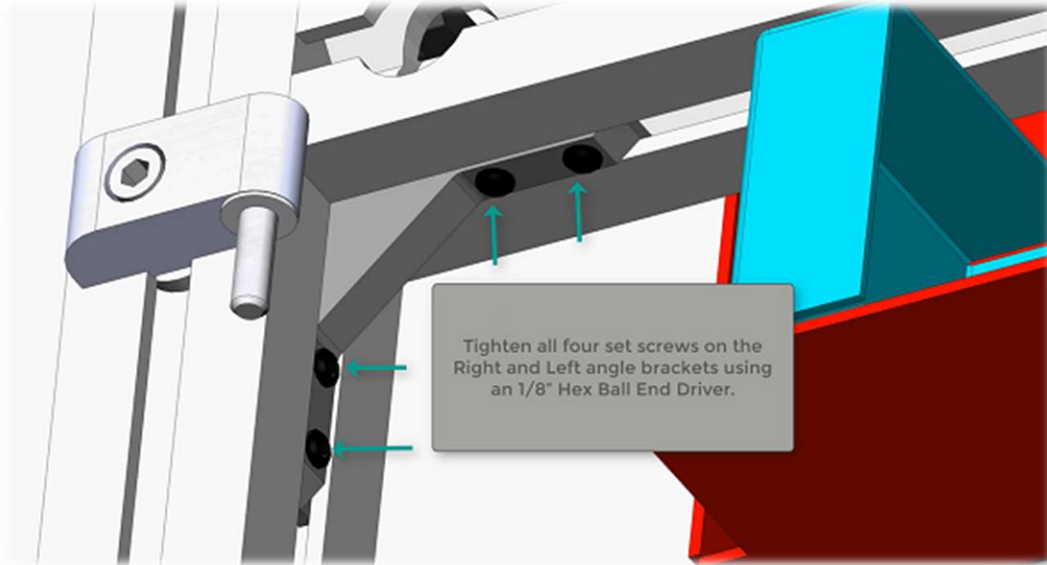

- Slide in 1 Anchor fastener into the top of each side of the front header assembly.

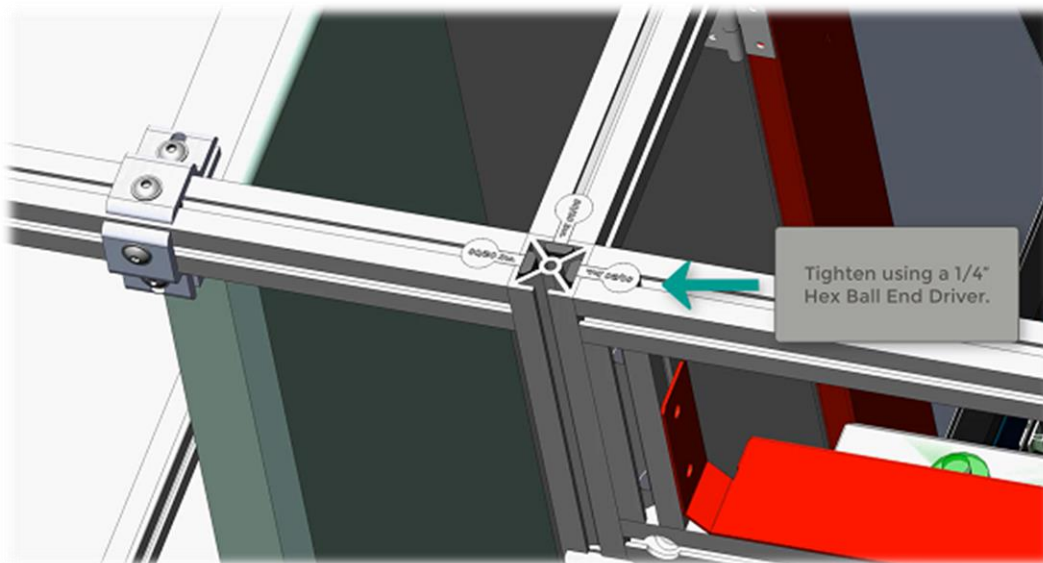

5) Install the Roof Panels of the ATC Portal.

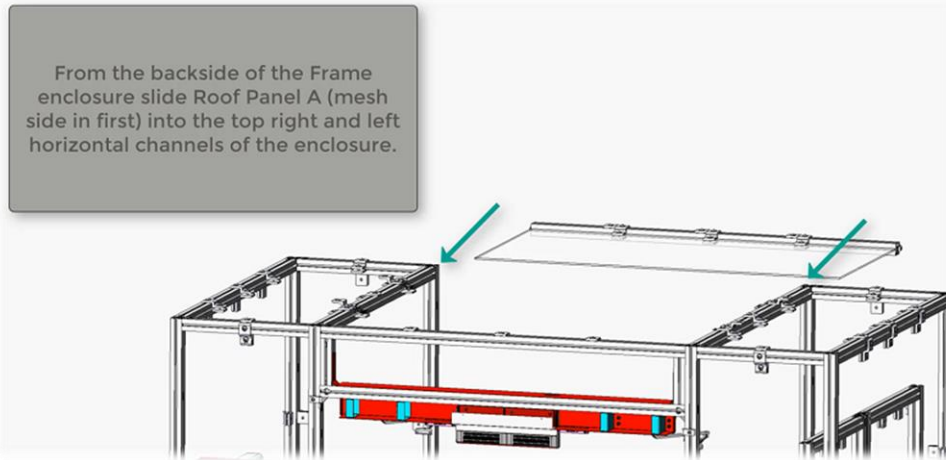

- Slide Roof Panel A until it is in the channel of the Front Header

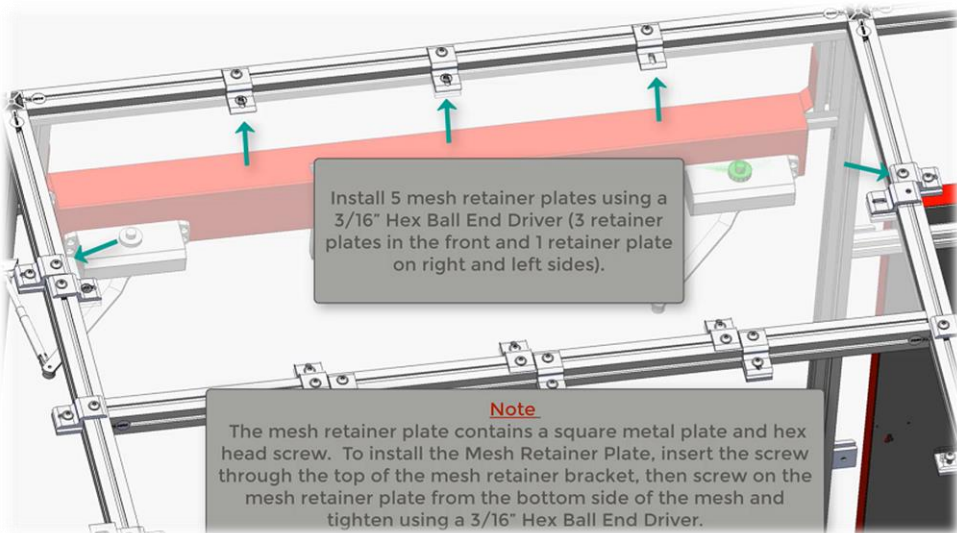
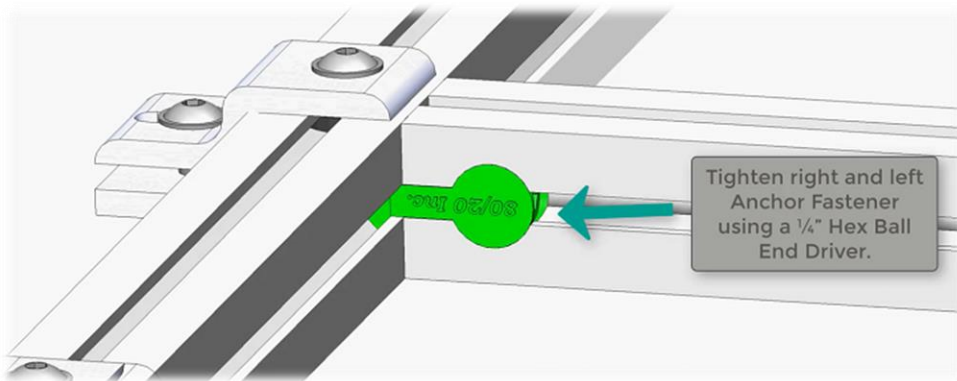

- Rotate the middle right and left side retainer brackets to face the middle of the enclosure. (This will be done on both Roof Panels A and B)

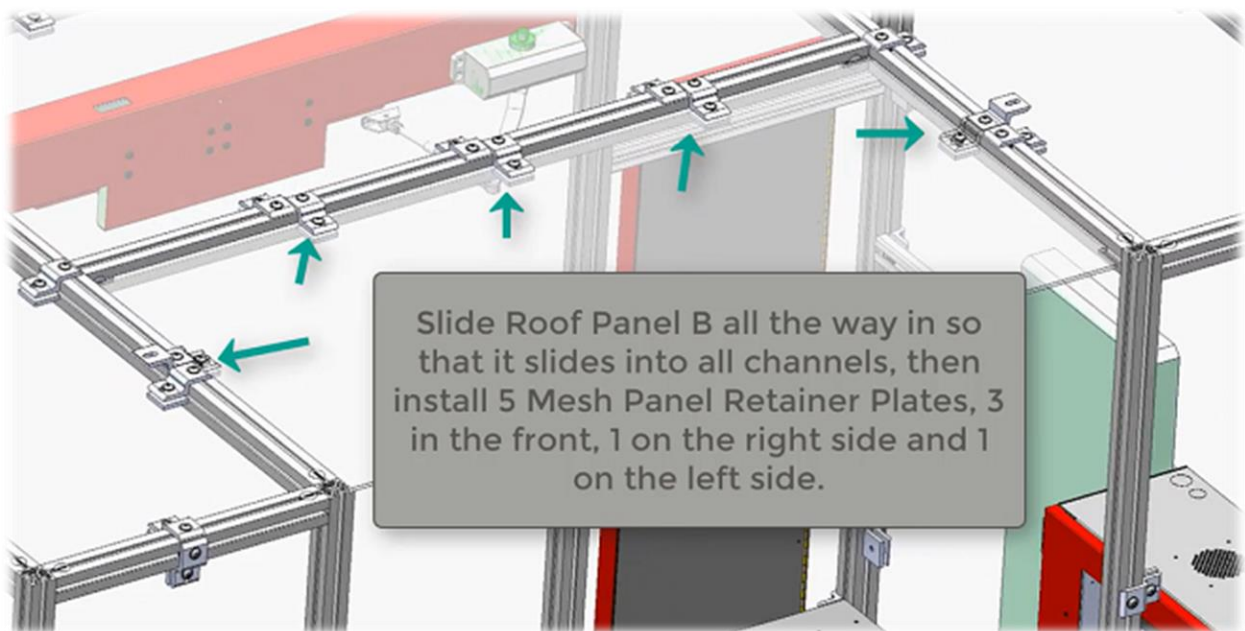
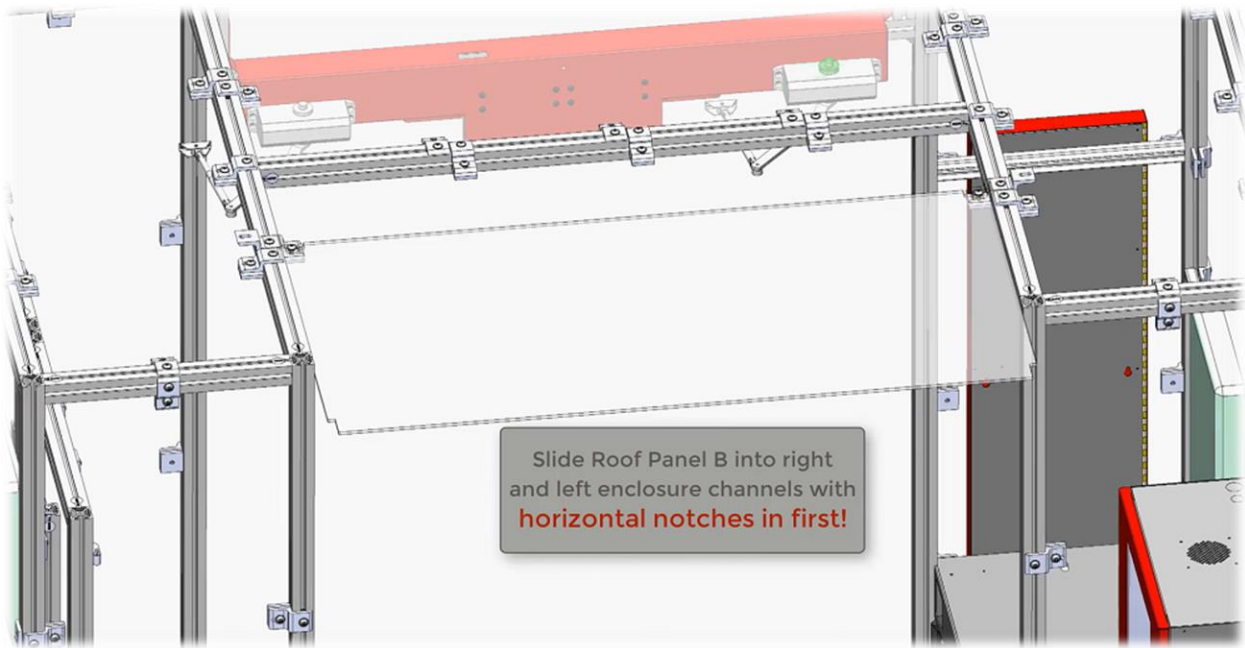

6) Install the Back Header assembly.

- Before sliding the header into place, you must flip an anchor fastener upside down and slide down both the right and left enclosure frame so that you can secure the underside of the header assembly when in place.

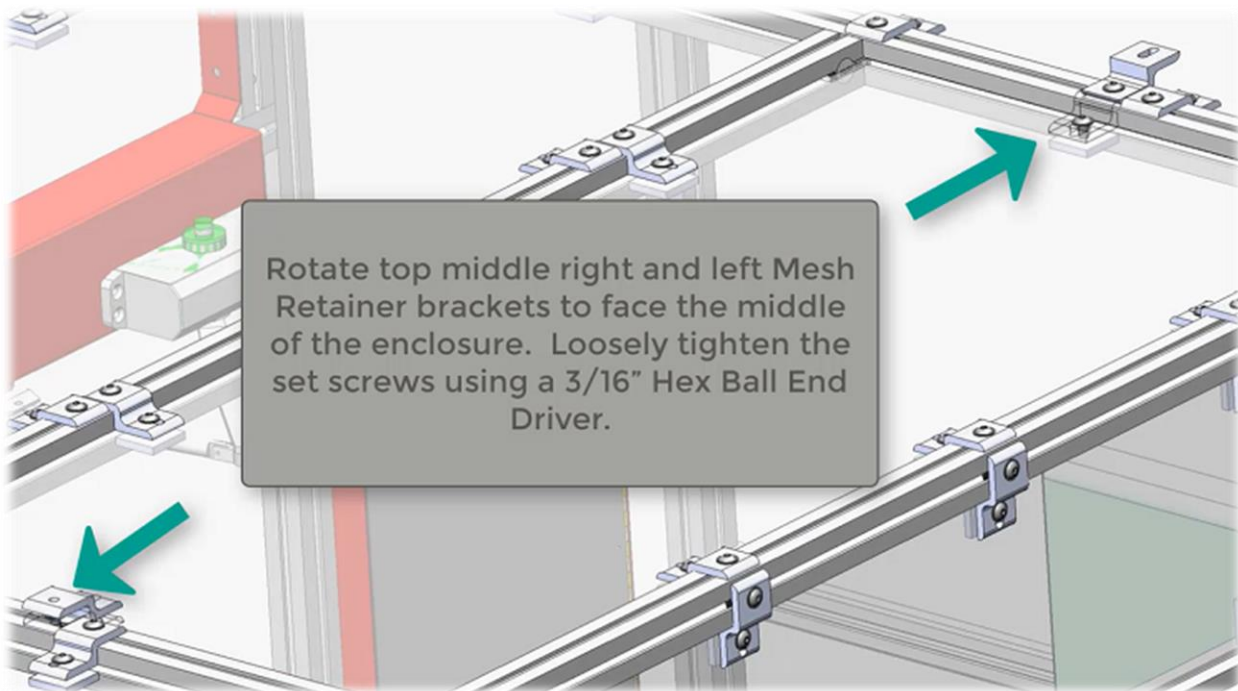
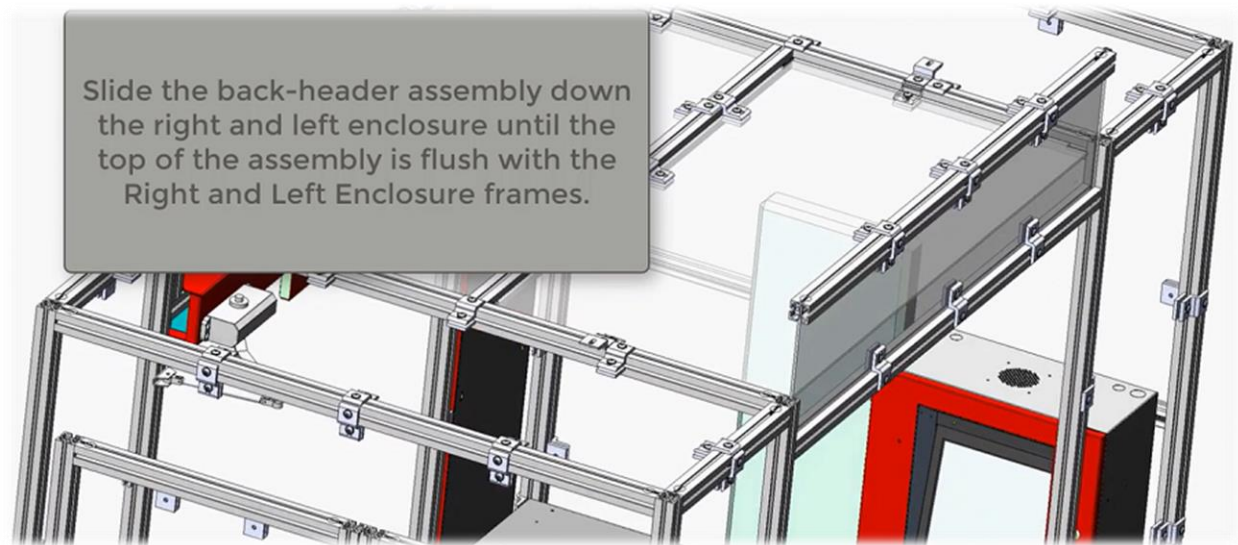

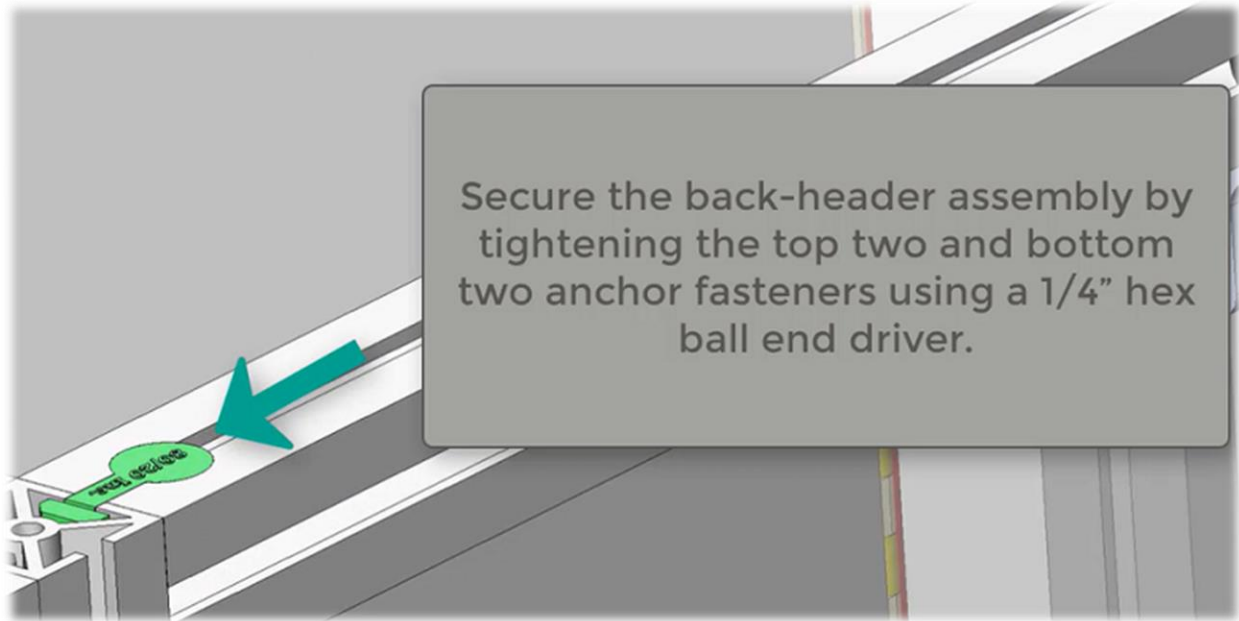

7) Install the doors.

- Be sure the top magnet sensors are close but not rubbing.
- The gap between the doors should be approximately 1/4".
- Confirm that when the doors open they do not hit the ground.
- Back doors do no lock or have sensors. Confirm they don't rub.

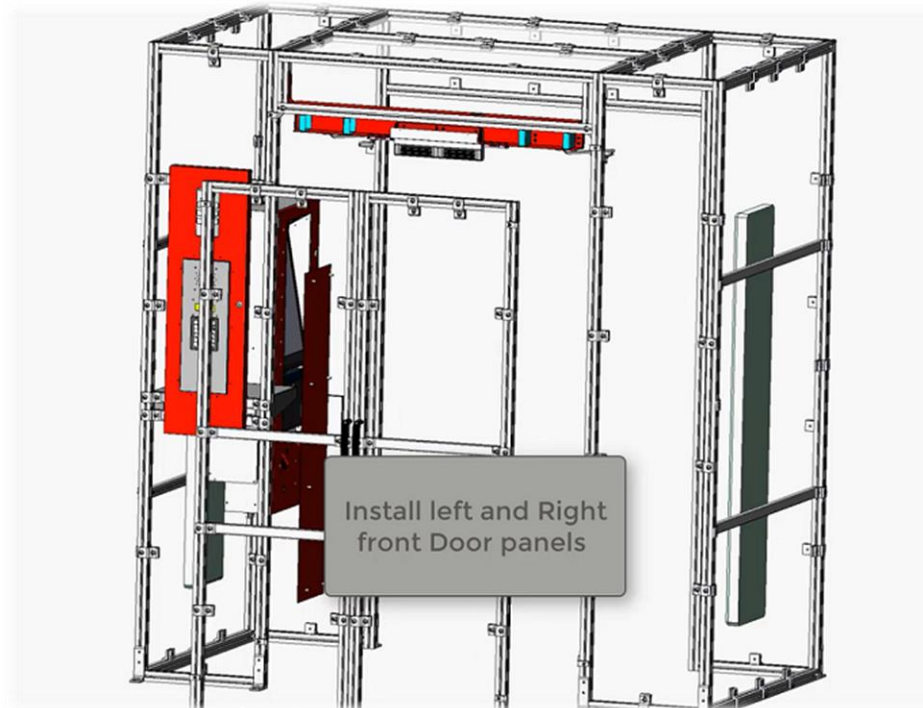



- When sliding the pins into place, loosen brackets on the door to ease with alignment.

8) Install the front cover for the header assembly.

- Be sure to route the wiring harness through the header assembly frame and connect the magnet lock and magnet sensors before securing the cover plate.

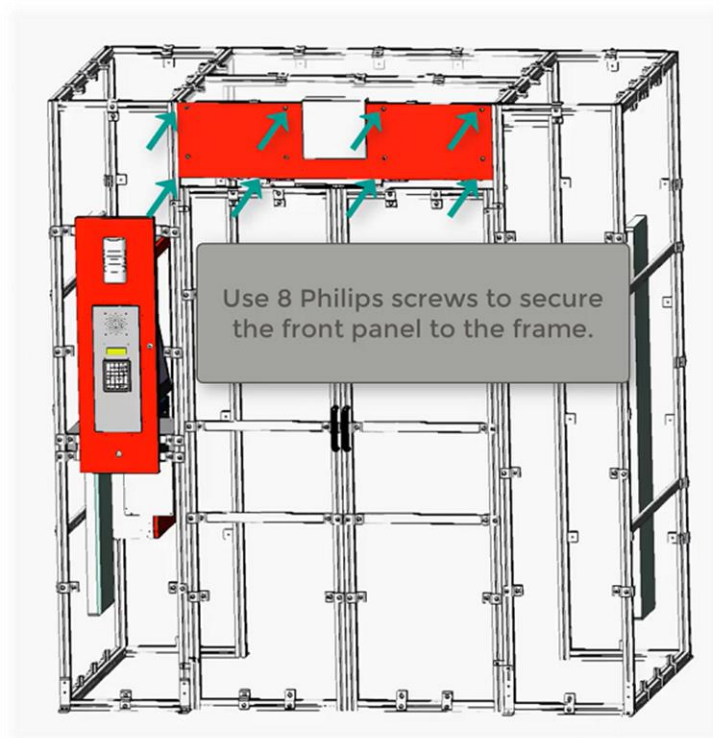

Camera Setup

- 1) The ATC Portal supports up to two cameras. The use of cameras is optional.
- 2) To confirm the cameras are functioning properly open the **Main Menu** by touching the gear icon in the top right corner of the screen.



- 3) From the Main Menu select Troubleshooting ->Diagnostics.

- 4) At the top of the **Diagnostics: Portal** screen select the **Camera** tab, then press the **Show Camera Stream** button.

- The diagnostics screens require the Diagnostics permission to access.
 - If a permissioned user is already logged in, they will need to press the diagnostic button (shown below) to start the diagnostics mode.



- If no user is logged in, the badge of a permissioned user will need to be scanned to start the diagnostics mode.

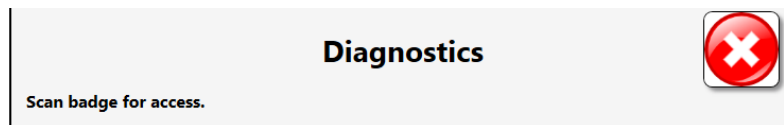

5) You should see video output for each camera. The recommended camera orientation is one camera pointing at the tool tray and the other pointing at the operators face and the door.

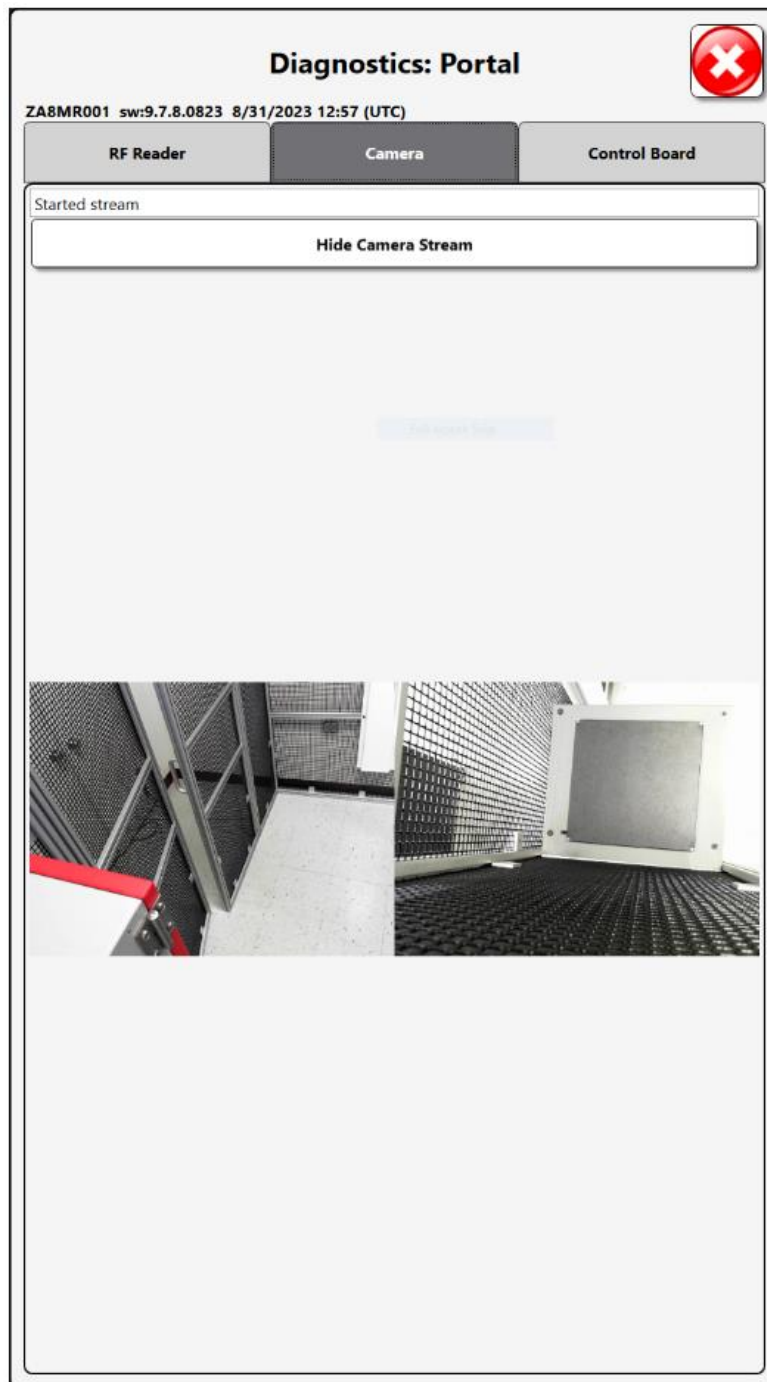

Receipt Printer Setup

1) To confirm the receipt printer is functioning properly open the **Main Menu** by touching the gear icon in the top right corner of the screen.



2) From the **Main Menu** select **I/T Settings**.

The **I/T Settings** screen requires the Network Setting permission to access.

If no user is logged in, the badge of a permissioned user will need to be scanned to access the I/T Settings screen

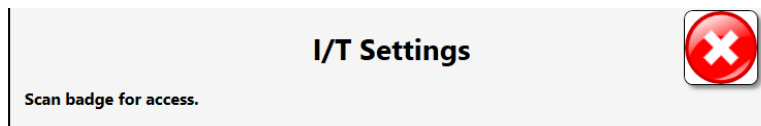

3) From the **I/T Setting** screen select **Printers**.

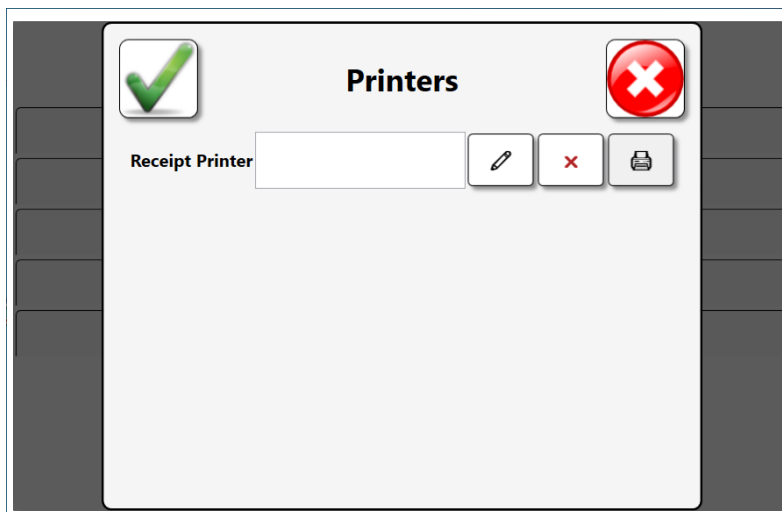

4) Confirm a printer is selected. If not, then press the edit button,  and select the desired printer model.

5) To print a test receipt, press the print button.



Troubleshooting

Body Mass Sensors

The reflective portion of the body mass sensor may be misaligned, which causes the system to indicate it is in use with a red light even though no one is in the portal.

Confirm the body mass sensors are pointed directly across from each other.

Front Door Magnets

To verify the sensors are functioning correctly Press the Emergency Exit button by the door once. This disengages the magnetic lock.

Open and close the front door while watching the Recent Events log on the idle screen. It should log a “Spontaneous Unlock” event when you open the door and a “Door Closed” event when the door is closed. Other events will also appear in the log. When the test is complete press the Emergency Exit button again to return the magnetic lock to normal behavior.

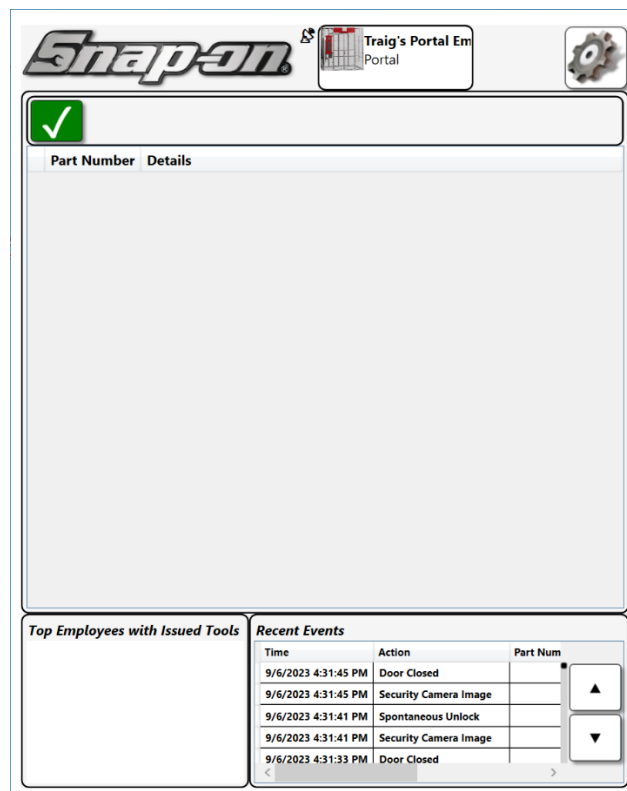

- If the previous test fails, fully power down the system and check the sensors. Disconnect the wires coming in from the sensor to the sensor board and verify continuity.

Emergency Exit Button

The emergency exit switch is a two-press button. If you press the switch once it will cut power to the magnets and remain off until the switch is pressed again to re-engage.

RFID Errors

Fine tuning of RFID Antenna Settings may resolve excessive RFID reading errors.

To adjust the Antenna setting, open the **Main Menu** by touching the gear icon in the top right corner of the screen. From the Main Menu select Troubleshooting ->Diagnostic

The diagnostics screens require the Diagnostics permission to access.

- If a permissioned user is already logged in, they will need to press the diagnostic button (shown below) to start the diagnostics mode.



- If no user is logged in then the badge of a permissioned user will need to be scanned to start the diagnostics mode.

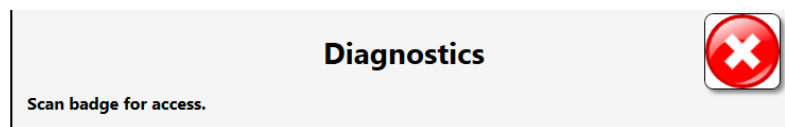

At the top of the **Diagnostics: Portal** screen select the RF Reader Tab

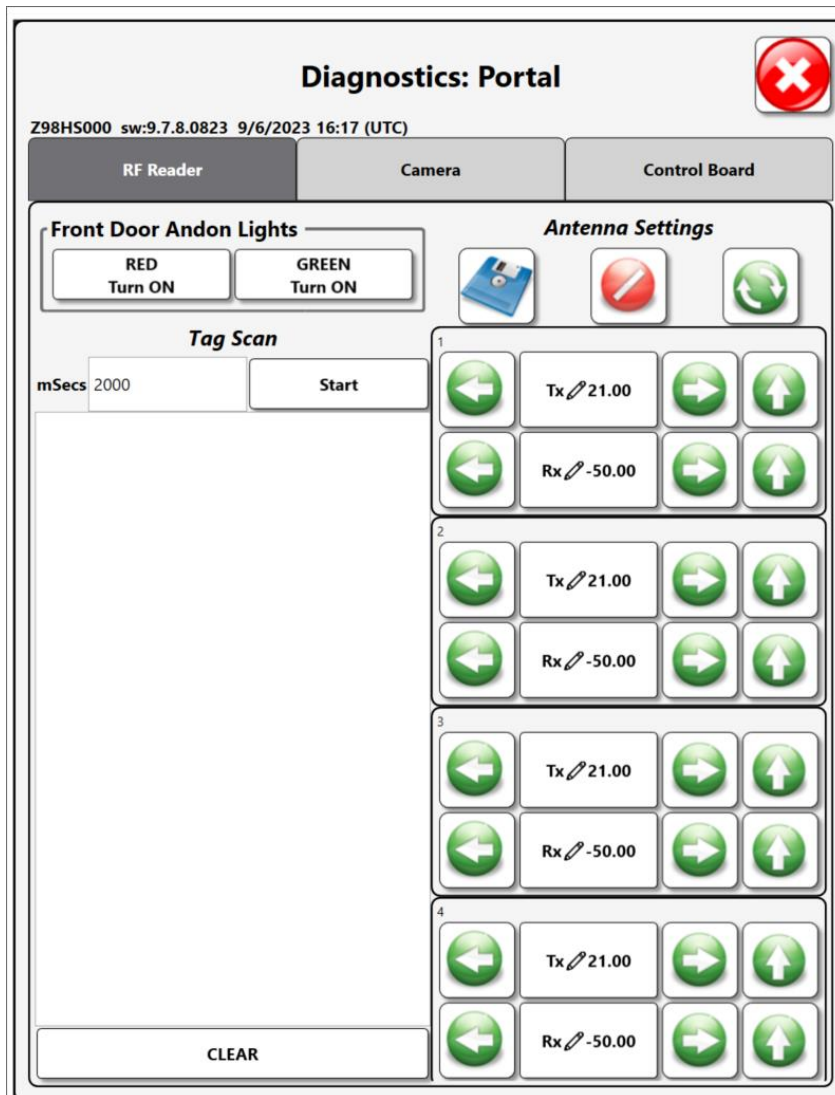

Tx controls the amount of power the antennas are outputting to charge the passive tags. Rx controls the sensitivity of the antennas. RFID antenna settings are a balance between reading all tags inside cage and not reading stray tags outside cage which can "leak" in. Increase Tx power/Rx Sensitivity if having trouble reading tags inside the cage, decrease them if reading stray tags from outside the cage.



USA

Snap-on Industrial

Automated Tool Control Group
309 Exchange Avenue
Conway, Arkansas 72032
Customer Service Number 1-800-272-2033
Fax: (501) 450-1585

Snap-on Tools International LLC

2801 80th Street
Kenosha, WI 53143
For General Inquiries 262-656-5200

Southeast Europe - Middle East

(SEEMEA) Division
PO Box 65 033
Athens 15410, Greece
Tel: +30 210 6724828
Fax: +30 210 6725754
E-mail: snap_mead@ath.forthnet.gr

United Kingdom

Industrial Sales Division - Snap-on Tools

Telford Way
38a, Telford Way, Kettering
Northants NN16 8UN, England
Tel: +44 (0) 1536 413904
Fax: +44 (0) 1536 413874
E-mail: industrialuk@snapon.com

Snap-on Tools (Australia) Pty LTD

National Distribution Centre
Unit 6/110 Station Road
P.O. Box 663
Seven Hills, NSW 1730 Australia
Tel: (61) 2-9837-9100
Fax: (61) 2-9624-2445
E-mail: sots.webmasters@snapon.com

**Snap-on Industrial Belgium & Luxembourg
Division**

SNA Germany GmbH
Auf dem Huls 5
40822 Mettmann
Germany
Tel: +32 - (0) 14-231967
Fax: +32 - (0) 14-232627
E-mail: industrial.be@snapon.com

Snap-on Industrial Germany Division

SNA Germany GmbH
Auf dem Huls 5
40822 Mettmann
Germany
Tel: +49-(0) 2104-950-911
Fax: +49-(0) 2104-950-999
E-mail: indus.germany@snapon.com

Snap-on Industrial Netherlands

SNA Germany GmbH
Auf dem Huls 5
40822 Mettmann Germany
Tel: +31-(0)20-5682664
Fax: +31-(0)20-5682660
E-mail: industrial.nl@snapon.com

Snap-on Tools Italia S.r.l

Via Bizet, 43/45
20092 Cinisello Balsamo (MI), Italy
Tel: +39 02 66 04 53 70
Fax: +39 02 61 29 78 15
E-mail: indus.italia@snapon.com

